

09 68 13

**TILE CARPETING**

**PART 1 – GENERAL**

**1.1 PURPOSE**

- A. This guideline is intended to provide useful information to the Professional Service Provider (PSP) to establish a basis of design. PSP is to apply the principles of this section such that the University of Texas at Arlington (UTA) may achieve a level of quality and consistency in the design and construction of their facilities. Deviations from these guidelines must be approved by UTA and may require justification through Life Cycle Cost (LCC) analysis and submitted to UTA for approval.

**1.2 LESSONS LEARNED AND DESIGN CONSIDERATIONS**

- A. X

**1.3 SECTION INCLUDES**

- A. Carpet tile, fully adhered.

**1.4 RELATED REQUIREMENTS**

- A. Section 01 61 16 – Volatile Organic Compound (VOC) Content Restrictions.
- B. Section 03 30 00 – Cast-in-Place Concrete: Restrictions on curing compounds for concrete slabs and floors.

**1.5 REFERENCE STANDARDS**

- A. ASTM D2859 - Standard Test Method for Ignition Characteristics of Finished Textile Floor Covering Materials; current edition.
- B. CRI (CIS) - Carpet Installation Standard; Carpet and Rug Institute; current edition.
- C. CRI 104 - Standard for Installation of Commercial Textile Floorcovering Materials; Carpet and Rug Institute; current edition.

**1.6 SUBMITTALS**

- A. See Division 01 for submittal procedures.
- B. Product Data: Provide data on specified products, describing physical and performance characteristics; sizes, patterns, colors available, and method of installation.
- C. Samples: Submit two carpet tiles illustrating color and pattern design for each carpet color selected.
- D. Submit two, \_\_\_\_\_ inch long samples of edge strip, base cap, stair nosing, and \_\_\_\_\_.
- E. Manufacturer's Installation Instructions: Indicate special procedures.
- F. Maintenance Data: Include maintenance procedures, recommended maintenance materials, and suggested schedule for cleaning.
- G. Maintenance Materials: Furnish the following for Owner's use in maintenance of project.
  - 1. See Division 01 for additional provisions.
  - 2. Extra Carpet Tiles: Quantity equal to 1 percent of total installed of each color and pattern installed.

**1.7 QUALITY ASSURANCE**

- A. Installer Qualifications: Company specializing in installing carpet tile with minimum three years documented experience and approved by carpet tile manufacturer.

**1.8 FIELD CONDITIONS**

- A. Store materials in area of installation for minimum period of 24 hours prior to installation.

**1.9 LESSONS LEARNED AND DESIGN CONSIDERATIONS**

- A. No carpet tiles shall be installed in tiered classrooms, especially those with radiused platforms.
- B. Carpet wall bases may be installed in settings such as Executive Offices, Conference Rooms, Reception Lobbies and other high profile spaces, which require a higher level of aesthetics.
- C. Rubber wall bases to be installed in Offices, Corridors, Breakrooms, Workrooms, Utility Closets and other

spaces not requiring a high level of aesthetics.

## **PART 2 – PRODUCTS**

### **2.1 MATERIALS**

- A. Carpet Tile: Fusion bonded, manufactured in one color dye lot:
  - 1. Product: \_\_\_\_\_ manufactured by \_\_\_\_\_.
  - 2. Tile Size: As selected by Architect.
  - 3. Color: As selected by Architect.
  - 4. Pattern: As selected by Architect.
  - 5. Surface Flammability Ignition: Pass ASTM D2859 (the "pill test").
  - 6. VOC Content: Comply with Division 01.

### **2.2 ACCESSORIES**

- A. Sub-Floor Filler: White premix latex; type recommended by flooring material manufacturer.
- B. Edge Strips:
  - 1. Anodized aluminum.
  - 2. Rubber.
- C. Adhesives: Acceptable to carpet tile manufacturer, compatible with materials being adhered; maximum VOC content as specified in Division 01.

## **PART 3 – EXECUTION**

### **3.1 EXAMINATION**

- A. Verify that sub-floor surfaces are smooth and flat within the tolerances specified for that type of work and are ready to receive flooring.
- B. Verify that wall surfaces are smooth and flat within the tolerances specified for that type of work, are dust-free, and are ready to receive carpet tile.
- C. Verify that sub-floor surfaces are dust-free and free of substances that could impair bonding of adhesive materials to sub-floor surfaces.
- D. Verify that concrete sub-floor surfaces are ready for flooring installation by testing for moisture emission rate and alkalinity in accordance with ASTM F710; obtain instructions if test results are not within limits recommended by carpet tile manufacturer and adhesive materials manufacturer.

### **3.2 PREPARATION**

- A. Remove sub-floor ridges and bumps. Fill low spots, cracks, joints, holes, and other defects with sub-floor filler.
- B. Apply, trowel, and float filler to achieve smooth, flat, hard surface. Prohibit traffic until filler is cured.
- C. Vacuum clean substrate.

### **3.3 INSTALLATION - STRIPS**

- A. Accurately saw cut substrate to install divider strips.
- B. Install strips straight and level to locations indicated.

### **3.4 INSTALLATION – FLOORING**

- A. Starting installation constitutes acceptance of sub-floor conditions.
- B. Install carpet tile in accordance with manufacturer's instructions.
- C. Install carpet tile in accordance with manufacturer's instructions and CRI 104.
- D. Blend carpet from different cartons to ensure minimal variation in color match.
- E. Cut carpet tile clean. Fit carpet tight to intersection with vertical surfaces without gaps.
- F. Lay carpet tile in square pattern, with pile direction parallel to next unit, set parallel to building lines.
- G. Lay carpet tile in patterns shown on the drawings.
- H. Locate change of color or pattern between rooms under door centerline.
- I. Fully adhere carpet tile to substrate.
- J. Trim carpet tile neatly at walls and around interruptions.
- K. Complete installation of edge strips, concealing exposed edges.

### **3.5 CLEANING, PROTECTING, AND CURING**

## GUIDE SPECIFICATIONS FOR DESIGN AND CONSTRUCTION DOCUMENTS

- A. Remove excess adhesive without damage, from floor, base, and wall surfaces.
- B. Clean and vacuum carpet surfaces.

### **PART 4 – APPENDIX**

#### 4.1 PRODUCT DATA / CUT SHEETS

- A. Mohawk Group, GT154 Faculty Remix Tile, 24"x24", color TBD
- B. Schluter – Same-height Transitions and Sloped Transition trims
- C. Roppe – Adapter & Transitions and Edge Guards
- D. Johnsonite - Adapter & Transitions and Edge Guards

END OF SECTION



**DESIGN**

Tufted Pile Weight:	<b>26.0 oz. per sq. yd. (882 g/m2)</b>
Product Type:	<b>Tile</b>
Construction:	<b>Tufted</b>
Minimum Sq. Yd.:	<b>No Minimum</b>
Surface Texture:	<b>Textured Multi Colored Loop</b>
Gauge:	<b>1/8 (31.50 rows per 10 cm)</b>
Density:	<b>6,500</b>
Weight Density:	<b>169,000</b>
Stitches Per Inch:	<b>8.3 (32.68 per 10 cm)</b>
Finished Pile Thickness:	<b>.144" (3.66 mm)</b>
Dye Method:	<b>Solution Dyed / Yarn Dyed</b>
Backing Material:	<b>EcoFlex NXT</b>
Fiber Type:	<b>Duracolor® Premium Nylon</b>
Fiber Technology:	<b>Duracolor® by Mohawk Group's Stain Resistant System. Passes GSA requirements for permanent stain resistant carpet.</b>
Pattern Repeat:	<b>Not Applicable</b>
Size:	<b>24" x 24" (.6096 m x .6096 m)</b>
Installation Method:	<b>Quarter Turn, Monolithic</b>
GSA Stain Release Rating:	<b>Pass</b>
Stain Release Technology:	<b>Permanent, Built into Fiber</b>
Soil Release Technology:	<b>Sentry Soil Protection</b>
Foot Traffic Recommendation TARR:	<b>Severe</b>

**SUSTAINABILITY**

IAQ Green Label Plus:	<b>CRI Green Label Plus GLP1171</b>
Pre-Consumer Recycled Content:	<b>54%</b>
Post-Consumer Recycled Content:	<b>1%</b>
NSF 140:	<b>EcoFlex NXT - NSF 140 Gold</b>
Declare Label:	<b>Declared Red List Free</b>

**PERFORMANCE**

Static:	<b>AATCC-134 Under 3.5 KV</b>
Flammability:	<b>ASTM E 648 Class 1 (Glue Down)</b>
Smoke Density:	<b>ASTM E 662 Less than 450</b>

**SERVICE**

Warranties:	<b>Lifetime Limited Carpet Tile Warranty, Lifetime Duracolor Stain Warranty, Lifetime Static</b>
-------------	--



143  
Exhilarating Pink

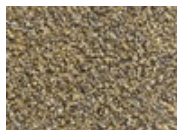

148  
Golden Jazz



341  
Brightened Red



379  
Crimson Spark



451  
Exciting Magenta



552  
Illuminating Aqua



556  
Invigorating Teal



565  
Regenerated Indigo



566  
Saturated Turquoise

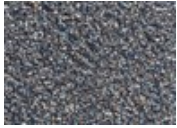

575  
Renewed Blue



599  
Pronounced Navy



665  
Refreshed Green



876  
Distinct Olive



885  
Latest Slate



927  
Revived Ash



978  
Keen Gray



989  
Greatest Charcoal

# FLOOR PROFILES



## INNOVATIVE SOLUTIONS FOR CERAMIC AND STONE TILE

### FINISHING, EDGE PROTECTION, AND TRANSITIONS

Because ceramic and stone tiles are inherently brittle, their exposed edges can chip and crack if left unprotected. Transitions between floor surfaces and at thresholds are particularly vulnerable to damage. Schluter-Systems offers a variety of profiles to provide edge protection and transitioning at thresholds and between adjacent surfaces, resulting in durable, maintenance-free tiled coverings. The profiles can be grouped into two categories: transitions between same-height surfaces and transitions between different-height surfaces.

### Application and Function

#### Same-height Transitions

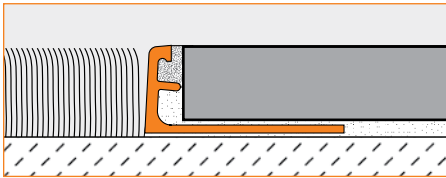

**1.1 Schluter®-SCHIENE** is designed to provide edging for tile coverings. Typical applications include edge protection where tile is bordered by carpet, at expansion joints, or as a decorative edging for stairs. SCHIENE is available in stainless steel, solid brass, aluminum, and anodized aluminum. The profile features a trapezoid-perforated anchoring leg, which is secured in the mortar bond coat beneath the tile, and an 87° sloped vertical wall section that transfers point loads to the substrate and surface covering while protecting tile edges from damage. SCHIENE, in solid brass, aluminum, and anodized aluminum, features a 5° sloped top flange and fillet at the anchoring leg/vertical section interface to enhance edge protection by reducing

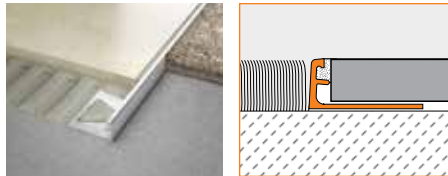

1.1 Schluter®-SCHIENE



1.6 Schluter®-DECO

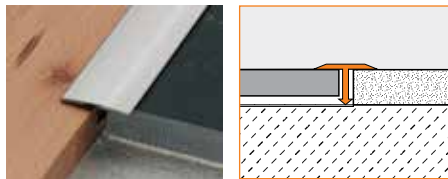

1.3 Schluter®-RENO-T

stresses on the tile, and, in sizes greater than 1/4" (6 mm), features an integrated joint spacer that establishes a defined joint cavity between the tile and the profile. The anchoring leg of SCHIENE, in all materials, is available with a special radius perforation "R" so that the profile can be used to form curves.

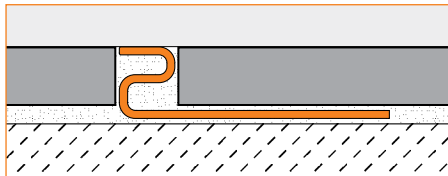

**1.6 Schluter®-DECO** is designed to provide decorative lines within tile coverings and edge protection at transitions from tile coverings to other same-height surface coverings, such as wood or carpet. The profile is available in stainless steel, solid brass, chrome-plated solid brass, and

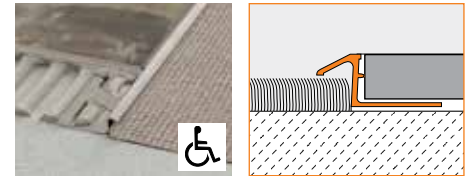

1.4 Schluter®-RENO-TK



1.2 Schluter®-RENO-U

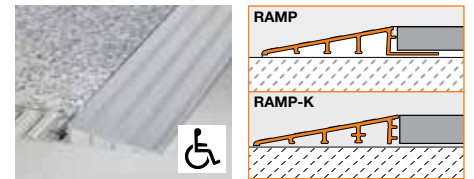

1.8 Schluter®-RENO-RAMP/-K

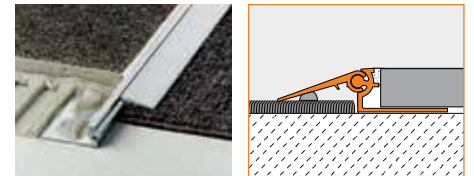

1.7 Schluter®-RENO-V

anodized aluminum. DECO features a trapezoid-perforated anchoring leg, which is secured in the mortar bond coat beneath the tile, and a 1/4" (6 mm)-wide visible surface that meets the high aesthetic requirements of showrooms, lobbies, galleries, exhibition booths, etc. The anchoring leg of DECO, in solid brass, chrome-plated solid brass, and anodized aluminum, is available with a special radius perforation "R" so that the profile can be used to form curves. DECO in chrome-plated brass requires a relatively large bending radius.

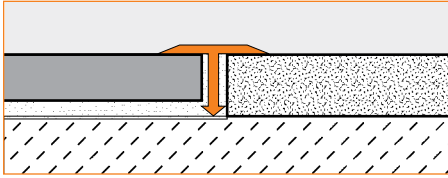

**1.3 Schluter®-RENO-T** is designed to provide transitions between existing same-height, hard-surface floor coverings (e.g., ceramic tile or natural stone, parquet flooring, concrete pavers, laminate, etc.), primarily in retrofit applications. The profile is available in stainless steel, solid brass, and anodized aluminum. RENO-T is installed within the existing joint cavity and overlaps adjoining surface materials, thus preventing edges from becoming damaged when subjected to mechanical stress. RENO-T, in brass and anodized aluminum size 9/14, is flexible in the lateral direction and can be used in curved applications.

### Different-height Transitions

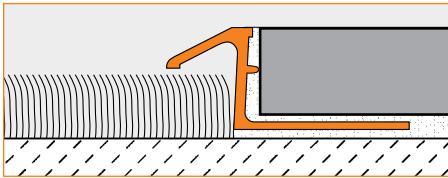

**1.4 Schluter®-RENO-TK** is designed to provide a smooth transition from tile coverings to floor coverings at lower elevations, typically carpet. The profile is available in stainless steel, solid brass, and anodized aluminum. RENO-TK features a trapezoid-perforated anchoring leg, which is secured in the mortar bond coat beneath the tile, and a sloped surface to eliminate trip hazards and protect tile edges. The 1/4" (6 mm) channel beneath the sloped flange of the profile hides and protects the cut edge of lower adjoining surface coverings. All sizes of the RENO-TK are compliant with the Americans with Disabilities Act (ADA). RENO-TK, in anodized aluminum, features an integrated joint spacer that establishes a defined joint cavity between the tile and the profile. The anchoring leg of RENO-TK, in solid brass and anodized aluminum, sizes 60 to 100, is available with a special radius perforation "R" so that the profile can be used to form curves.

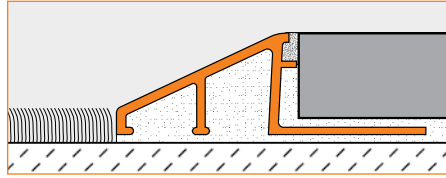

**1.2 Schluter®-RENO-U** is designed to provide a smooth transition between tile coverings and floor coverings at lower elevations or finished concrete. The profile is available in stainless steel, solid brass, and anodized aluminum. RENO-U features a trapezoid-perforated anchoring leg, which is secured in the mortar bond coat beneath the tile, and a sloped surface (approximately 25°) that eliminates trip hazards and protects tile edges. The leading edge of the profile abuts the lower surface covering, typically VCT. RENO-U, in aluminum, features an integrated joint spacer that establishes a defined joint cavity between the tile and the profile. In installations where the leading edge abuts a lower surface covering, all sizes of RENO-U, except the 3/4" (20 mm) and 11/16" (17.5 mm), are compliant with the Americans with Disabilities Act (ADA). In installations where the leading edge rests on top of the lower floor covering (e.g., finished concrete), the 3/4" (20 mm), 11/16" (17.5 mm), and 9/16" (15 mm) sizes are not ADA-compliant.

**Note:** When using Schluter® uncoupling membranes with RENO-U profiles, factor in the thickness of the membrane over the anchoring leg when selecting the profile height.

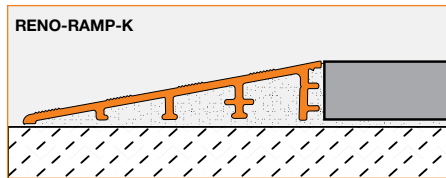
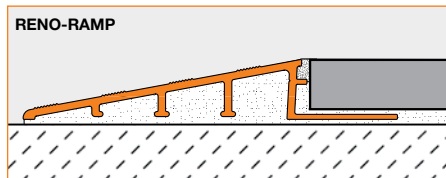

**1.8 Schluter®-RENO-RAMP** is designed to provide a smooth transition between tile coverings and floor coverings at lower elevations or finished concrete, particularly in commercial applications where wheel carts are used (e.g., bakeries, hospitals, etc.). The profile

is available in anodized aluminum. RENO-RAMP features a trapezoid-perforated anchoring leg, which is secured in the mortar bond coat beneath the tile, and a sloped transition surface that terminates at the height of the tile edge. The profile protects tile edges and provides a sloped surface to eliminate trip hazards and allow easy access for wheel carts. RENO-RAMP features an integrated joint spacer that establishes a defined joint cavity between the tile and the profile.

**Note:** When using Schluter® uncoupling membranes with RENO-RAMP profiles, factor in the thickness of the membrane over the anchoring leg when selecting the profile height. **Schluter®-RENO-RAMP-K** is a variant of the profile without an anchoring leg. RENO-RAMP-K is installed adjacent to existing floor coverings, e.g., retrofitting between existing floor coverings and bare concrete without having to disturb the existing flooring. All sizes of RENO-RAMP, except sizes 9/16" (15 mm) and 3/4" (20 mm), are compliant with the Americans with Disabilities Act (ADA).

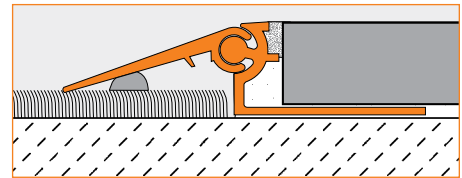

**1.7 Schluter®-RENO-V** is designed to provide a smooth transition between tile coverings and floor coverings at lower elevations. The profile is available in anodized aluminum. RENO-V features a trapezoid-perforated anchoring leg, which is secured in the mortar bond coat beneath the tile, and a movable transition arm that allows the profile to adjust to the height of the adjacent floor covering via a ball-and-socket joint. The profile protects tile edges and provides a sloped surface to eliminate trip hazards. RENO-V features an integrated joint spacer that establishes a defined joint cavity between the tile and the profile. RENO-V is also suitable for heavy-duty applications (e.g., entrances to garages or loading docks). In such cases, the adjustable arm is backfilled with mortar.



SafeMax®

## edge guards

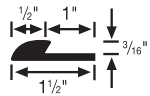

### #34 underlap carpet edge 3/16"

- 3/16" butting gauge; fast taper; long flange
- Installation Radius: 6 ft.
- 16 9-ft. secs. per ctn. (144 ft.)

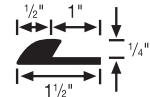

### #35 underlap carpet edge 1/4"

- 1/4" butting gauge
- Installation Radius: 8 ft.
- 16 9-ft. secs. per ctn. (144 ft.)

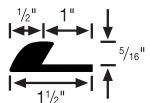

### #36 underlap carpet edge 5/16"

- 5/16" butting gauge
- Installation Radius: 6 ft.
- 16 9-ft. secs. per ctn. (144 ft.)

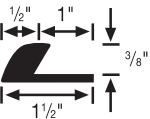

### #37 underlap carpet edge 3/8"

- 3/8" butting gauge
- Installation Radius: 6 ft.
- 16 9-ft. secs. per ctn. (144 ft.)

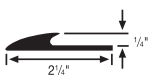

### #38 glue-down carpet edge 1/4"

- 1/4" butting gauge undercut; long flange smooth taper
- Installation Radius: 5.5 ft.
- 10 9-ft. secs. per tube (90 ft.)



### #39 glue-down carpet edge 5/16"

- 5/16" butting gauge undercut
- Installation Radius: 5.5 ft.
- 10 9-ft. secs. per tube (90 ft.)

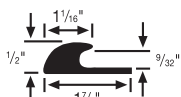

### #40 carpet edge guard 9/32"

- 9/32" butting gauge undercut; long flange, faster taper than #38
- Installation Radius: 6 ft.
- 10 9-ft. secs. per tube (90 ft.)

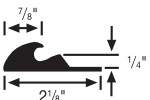

### #41 tackless carpet bar 1/4"

- 1/4" butting gauge to accept tackless strip; deep undercut; long flange
- Installation Radius: 12 ft.
- 10 9-ft. secs. per tube (90 ft.)

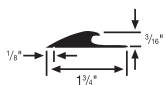

### #42 custom carpet edging 3/16"

- Notched at 1/8"; undercut 3/16"; long, smooth taper (similar to #38 and #39)
- Installation Radius: 5.5 ft.
- 10 9-ft. secs. per tube (90 ft.)

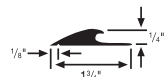

### #43 custom carpet edging 1/4"

- Same as #42 above except undercut 1/4"; notched at 1/8"
- Installation Radius: 5.5 ft.
- 10 9-ft. secs. per tube (90 ft.)



## adapter & transitions

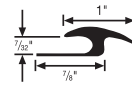

### #50 tile/carpet joiner 7/32"

- Provides smooth transition between carpet and tile
- Installation Radius: 5 ft.
- 10 9-ft. secs. per tube (90 ft.)

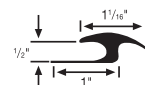

### #56 tile/carpet joiner 1/2"

- Similar to #50; wider opening fits wood and ceramic tile
- Installation Radius: 5 ft.
- 10 9-ft. secs. per tube (90 ft.)

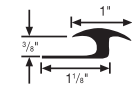

### #60 tile/carpet joiner 3/8"

- Similar to #50; wider opening fits wood and ceramic tile
- Installation Radius: 5 ft.
- 10 9-ft. secs. per tube (90 ft.)

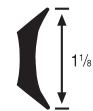

### #44 fillet strip

- Superb backing for flashing up the wall; color may vary due to 100% recycled content
- Installation Radius: 1 inch
- 16 9-ft. pcs. per ctn. (144 ft.)

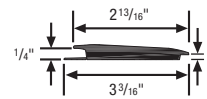

### #65 rolling traffic transition 1/4" to 1/8"

- Transitions 1/4" to 1/8" materials
- Installation Radius: 12 ft.
- 10 9-ft. secs. per tube (90 ft.)

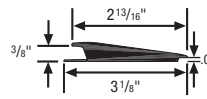

### #66 rolling traffic transition 3/8" to .080"

- Transitions 3/8" to .080" materials
- Installation Radius: 12 ft.
- 10 9-ft. secs. per tube (90 ft.)

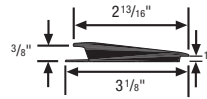

### #67 rolling traffic transition 3/8" to 1/8"

- Transitions 3/8" to 1/8" materials
- Installation Radius: 12 ft.
- 5 9-ft. secs. per tube (45 ft.)

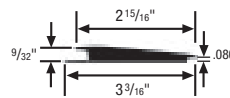

### #73 rolling traffic transition 1/4" to .080"

- Transitions 1/4" to .080" materials
- Installation Radius: 12 ft.
- 10 9-ft. secs. per tube (90 ft.)

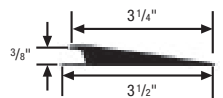

### #74 rolling traffic transition 3/8"

- Transitions 3/8" materials to subfloor
- Installation Radius: 12 ft.
- 10 9-ft. secs. per tube (90 ft.)

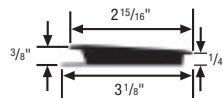

### #75 rolling traffic transition 3/8" to 1/4"

- Transitions 3/8" to 1/4" materials
- Installation Radius: 12 ft.
- 10 9-ft. secs. per tube (90 ft.)





# nosings

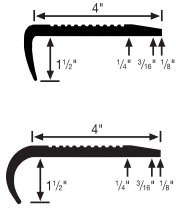

## #1 & #2 commercial stair nosing

- For butting to resilient flooring. 2" abrasive strip or ribbed insert available on #1 only; ribbed safety surface
- Installation Radius: 11 ft.
- 5 9-ft. secs. per tube (45 ft.)

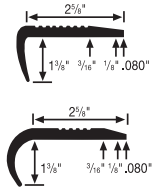

## #3 & #4 residential stair nosing

- Same features as #1 and #2 but lighter weight, smaller step area
- Installation Radius: 11 ft.
- 10 9-ft. secs. per tube (90 ft.)

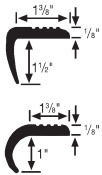

## #5 & #6 domestic stair nosing

- For very light-duty applications
- Installation Radius: 11 ft.
- 10 9-ft. secs. per tube (90 ft.)

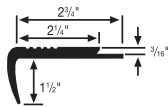

## #7 underlap carpet nosing

- For low pile carpet; standard nose (1-1/2")
- Installation Radius: 11 ft.
- 10 9-ft. secs. per tube (90 ft.)

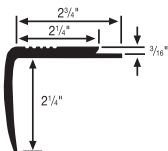

## #m-07 modified underlap stair nosing

- Same as #7 above except longer nose (2-1/4")
- Installation Radius: 12 ft.
- 5 9-ft. secs. per tube (45 ft.)

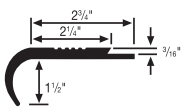

## #8 underlap stair nosing

- Flange-type design for 3/16" low pile carpet; ribbed
- Installation Radius: 11 ft.
- 10 9-ft. secs. per tube (90 ft.)



# corner guard

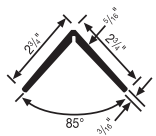

## #19 corner guard

length: 54" (standard)

- Heavy-duty protection; special order to 9 ft.
- Installation Radius: Not Applicable.
- 6 54" pcs. per ctn.
- 5 pcs. per ctn. on special order sizes

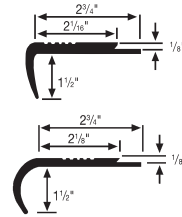

## #9 & #10 underlap stair nosing

- Flange-type design for 1/8" low pile carpet; ribbed
- Installation Radius: 12 ft.
- 5 9-ft. secs. per tube (45 ft.)

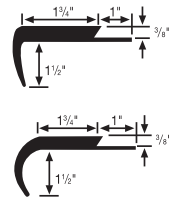

## #11 & #12 single flange carpet stair nosing

- Smooth surface; heavy-duty design; 3/8" butting gauge
- Installation Radius: 12 ft.
- 5 9-ft. secs. per tube (45 ft.)

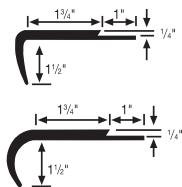

## #13 & #14 single flange carpet stair nosing

- Smooth surface; light-duty design; 1/4" butting gauge
- Installation Radius: 12 ft.
- 5 9-ft. secs. per tube (45 ft.)

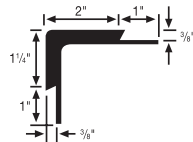

## #15 double flange carpet stair nosing

- Smooth surface; 3/8" butting gauge
- Installation Radius: 12 ft.
- 5 9-ft. secs. per tube (45 ft.)

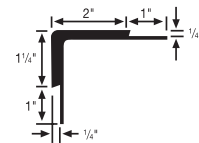

## #16 double flange carpet stair nosing

- Smooth surface; 1/4" butting gauge
- Installation Radius: 12 ft.
- 5 9-ft. secs. per tube (45 ft.)

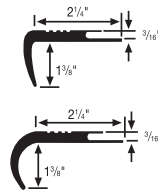

## #17 & #18 undercut carpet nosing

- 3/16" undercut; ribbed safety surface
- Installation Radius: 12 ft.
- 5 9-ft. secs. per tube (45 ft.)



For colors, see page 5





SafeTMax®

## reducers

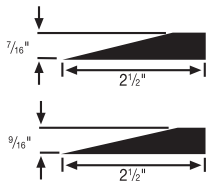

- #20 & #49 transitional reducer**  
7/16" (#20) 9/16" (#49)
- Choose 7/16" or 9/16" butting gauge;
  - Installation Radius: 6 ft.
  - 10 9-ft. secs. per tube (90 ft.)

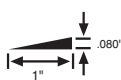

- #21 reducer strip .080" for resilient floor**
- Butt to reducer for .080" material; 1" beveled width for good transition
  - Installation Radius: 6 ft.
  - 16 9-ft. secs. per ctn. (144 ft.)



- #22 & #48 reducer strip**  
1/8" (#22) 3/32" (#48)
- Same as #21 except choose 1/8" or 3/32" butting gauge
  - Installation Radius: 6 ft.
  - 16 9-ft. secs. per ctn. (144 ft.)

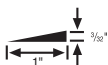

- #23 reducer strip 3/16"**
- 3/16" butting gauge; 1-5/16" width for smooth, neat transition
  - Installation Radius: 6 ft.
  - 16 9-ft. secs. per ctn. (144 ft.)

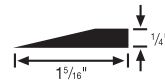

- #24 reducer strip 1/4"**
- Same as #23 except 1/4" butting gauge
  - Installation Radius: 4 ft.
  - 16 9-ft. secs. per ctn. (144 ft.)

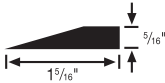

- #25 reducer strip 5/16"**
- Same as #23 except 5/16" butting gauge
  - Installation Radius: 2 ft.
  - 16 9-ft. secs. per ctn. (144 ft.)

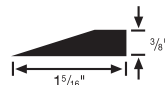

- #26 reducer strip 3/8"**
- Same as #23 except 3/8" butting gauge
  - Installation Radius: 2 ft.
  - 16 9-ft. secs. per ctn. (144 ft.)

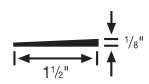

- #45 reducer strip 1/8"**
- 1/8" butting gauge; 1-1/2" width for smooth transition
  - Installation Radius: 8 ft.
  - 16 9-ft. secs. per ctn. (144 ft.)

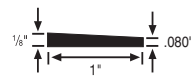

- #59 reducer strip 1/8" tapering to .080"**
- Special design for installations where a 1/8" must meet an .080" floor
  - Installation Radius: 4 ft.
  - 16 9-ft. secs. per ctn. (144 ft.)



## cove caps

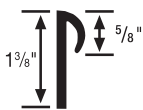

- #28 carpet cove cap (round)**
- Trim for coved carpet; undercut 3/16" (flexible); angle 45°
  - Installation Radius: 4 inches
  - 16 9-ft. secs. per ctn. (144 ft.)

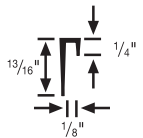

- #46 cove cap (square)**
- Undercut 1/8"; cap for coved carpets and wall paneling; angle 45°
  - Installation Radius: 4 inches
  - 16 9-ft. secs. per ctn. (144 ft.)

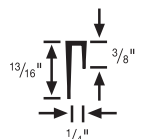

- #47 cove cap (square)**
- Undercut 1/4"; cap for coved carpets and wall paneling; angle 45°
  - Installation Radius: 4 inches.
  - 16 9-ft. secs. per ctn. (144 ft.)



## thresholds

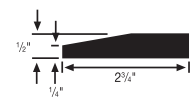

- #32 half threshold**
- Butts to carpet, ceramic tile; wear resistant; colors; black, brown, black brown, fawn, dark gray and camel
  - Installation Radius: 9 ft.
  - 12 pcs. per ctn.; 30", 36", 42", 48", 60", 72"

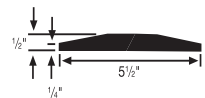

- #33 full threshold**
- Wear resistant compound; colors; black, brown, black brown, fawn, dark gray and camel
  - Installation Radius: Zero
  - 6 pcs. per ctn.; 30", 36", 42", 48", 60", 72"



## landing trim

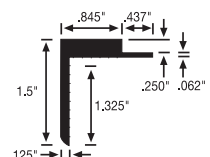

- #57 landing trim**
- Special design for open stairwells; length 98"
  - Installation Radius: 3 ft.
  - 10 98" pcs. per tube (81.7 ft.)



proudly made in the USA

For colors, see page 5



## nosings

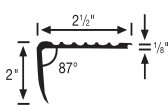

### #202 overlap stair nosing 1/8"

- Square nosing; ribbed safety surface
- Installation Radius: 11 ft.
- 10 12-ft. secs. per ctn. (120 ft.)

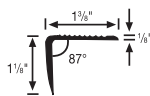

### #203 domestic stair nosing 1/8"

- For light-duty applications; installs over vinyl tile or sheet goods
- Installation Radius: 11 ft.
- 5 12-ft. secs. per ctn. (60 ft.)

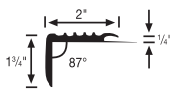

### #204 undercut carpet nosing 1/4"

- Heavy-duty for 1/4" and 5/16" carpet
- Installation Radius: 11 ft.
- 5 12-ft. secs. per ctn. (60 ft.)

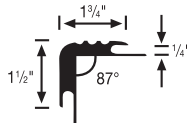

### #206 double undercut stair nosing 1/4"

- For 1/4" and 5/16" carpet
- Installation Radius: 11 ft.
- 5 12-ft. secs. per ctn. (60 ft.)

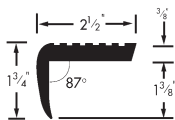

### #207 vinyl 3/8" butt stair nosing

- 3/8" butt stair nosing for carpet and Rop-Cord® tile
- Installation Radius: 10 ft., color Black only
- 5 12-ft. secs. per ctn. (60 ft.)

## corner guard

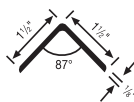

### #166 corner guard 1/8" length: 54" (standard)

- 1-1/2" returns; standard length 54" (special order to 9 ft., minimum quantities required)
- Installation Radius: Not Applicable.
- 12 54" pcs. per ctn. (54 ft. on standard orders)

## tracks

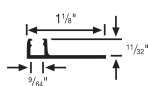

### #155 single flange track

- Works with #152, #154, #175 and #179; color Black only
- Installation Radius: Zero
- 10 12-ft. pcs. per ctn. (120 ft.)

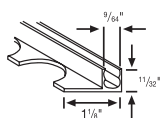

### #178 FLEXI-TRACK® single flange track

- Works with #152, #154, #175 and #179; flexible, contours easily; color Black only
- Installation Radius: 6 ft.
- 20 12-ft. pcs. per ctn. (240 ft.)

## cove caps

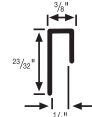

### #158 cove cap (square) 1/4"

- Cap for coved carpets and wall paneling
- Installation Radius: 1 ft.
- 40 12-ft. secs. per ctn. (480 ft.)

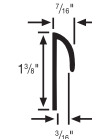

### #161 carpet cove trim

- For coved carpet; undercut 3/16" (flexible)
- Installation Radius: 10 ft.
- 20 12-ft. secs. per ctn. (240 ft.)

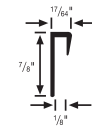

### #165 cove cap (square) 1/8"

- Cap for coved sheet vinyl; undercut 1/8"
- Installation Radius: 1 ft.
- 50 12-ft. secs. per ctn. (600 ft.)



### #193 vinyl flash cap height: 4"

- Vinyl fillet strip and cove cap in one product; use for vinyl sheet or carpet up to 1/4" thick
- Installation Radius: 4 inches
- 20 5-ft. secs. per ctn. (100 ft.)

## fillets & tub moldings

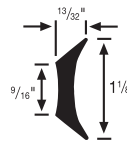

### #167 fillet strip

- Superb backing for flashing up the wall color may vary due to 100% recycled content; angle 45°
- Installation Radius: 1 ft.
- 5 20-ft. coils per ctn. (100 ft.)

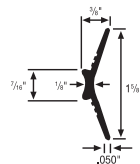

### #188 cove stick

- Superb backing for flashing up the wall color Neutral only; angle 45°
- Installation Radius: 2 ft.
- 100 5-ft. pcs. per ctn. (500 ft.)

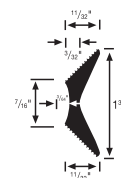

### #189 fillet molding

- Superb backing for flashing up the wall color Snow only; angle 45°
- Installation Radius: 1 ft.
- 25 5-ft. pcs. per ctn. (125 ft.)

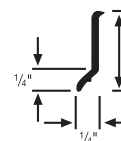

### #190 & #191 tub molding 1" (#190) 1-1/2" (#191)

- High-gloss finish, self-stick backing, 1" or 1-1/2" cove for tubs, counters, shelves; colors Snow and Almond only; angle 45°
- Installation Radius: 1 ft.
- 24 5-ft. pcs. per ctn. (120 ft.)

## reducers

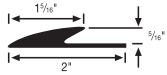

### #156 glue-down reducer 5/16"

- 5/16" butting gauge undercut; long flange, smooth taper
- Installation Radius: 18 ft.
- 5 12-ft. secs. per ctn. (60 ft.)

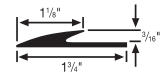

### #160 glue-down reducer 3/16"

- Undercut 3/16"; flange and transition combined; smooth transition
- Installation Radius: 10 ft.
- 20 12-ft. secs. per ctn. (240 ft.)

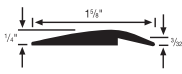

### #168 underslung reducer

- Binder-bar edging for resilient flooring; undercut .115" for use with 1/16" to 1/8" material
- Installation Radius: 3 ft.
- 2 35-ft. coils per ctn. (70 ft.)

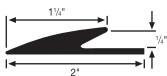

### #169 glue-down reducer 1/4"

- 1/4" undercut; long flange, smooth taper
- Installation Radius: 10 ft.
- 5 12-ft. secs. per tube (60 ft.)

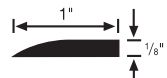

### #172 tile reducer 1/8"

- Beveled edge for resilient flooring; 1/8" butting edge
- Installation Radius: 18 ft.
- 50 3-ft. secs. per ctn. (150 ft.)

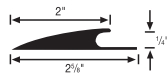

### #174 glue-down reducer 1/4"

- Undercut 1/4" with 2" transition
- Installation Radius: 11 ft.
- 10 12-ft. secs. per ctn. (120 ft.)

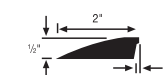

### #176 multi-use reducer 1/2"

- For carpet, ceramic tile or wood floors
- Installation Radius: 6 ft.
- 10 12-ft. secs. per ctn. (120 ft.)

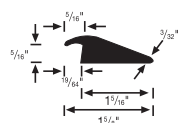

### #196 carpet reducer 3/8"

- Designed especially for 3/8" carpet
- Installation Radius: 10 ft.
- 10 12-ft. secs. per ctn. (120 ft.)



## wall accessories



### #350 quarter round

- Designed to outperform wood to complement a tread, tile or base job
- Installation Radius: 3 ft.
- 10 12-ft. pcs. per ctn. (#350) or 40' coil (#C350)



## adapters / transitions

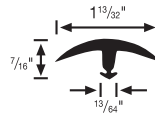

### #152 snap-down divider

- 1-13/32" wide removable section for joining carpets
- Installation Radius: 6 ft.
- 20 12-ft. secs. per ctn. (240 ft.)

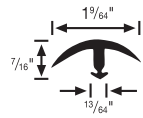

### #154 snap-down edging

- 1-9/64" wide removable section for joining carpet to tile
- Installation Radius: 6 ft.
- 20 12-ft. secs. per ctn. (240 ft.)

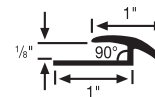

### #159 tile carpet joiner

- Provides smooth carpet/ tile transition
- Installation Radius: 10 ft.
- 20 12-ft. secs. per tube (240 ft.)

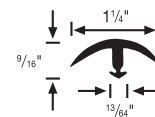

### #175 snap-down edging

- 1-1/4" wide removable section for joining tile to wood
- Installation Radius: 6 ft.
- 20 12-ft. secs. per ctn. (240 ft.)

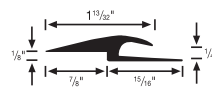

### #177 tile carpet joiner

- Joins 1/4" carpet to 1/8" tile
- Installation Radius: 10 ft.
- 5 12-ft. secs. per ctn. (60 ft.)

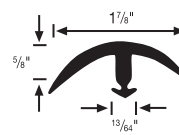

### #179 snap-down super edge

- 1-7/8" wide removable section for joining carpet to wood/ceramic
- Installation Radius: 6 ft.
- 5 12-ft. secs. per ctn. (60 ft.)

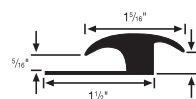

### #182 ceramic/wood carpet transition 3/8"

- Molding for joining 5/16" carpet to 3/8" ceramic/wood flooring
- Installation Radius: 12 ft.
- 10 12-ft. secs. per tube (120 ft.)

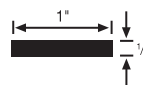

### #195 feature strip

- Designed to transition between 1/8" tiles or add interest to floor design
- Installation Radius: 3 ft.
- 50 3-ft. pcs. per ctn. (150 ft.)



proudly made in the



For colors, see page 4

**ROPPE.**  
Proven. Flooring. Experiences.

For representation of actual size, enlarge CAD drawing 333% on a photocopy.

We've identified Color Foundations neutrals in the following way: **WB** (warm beige), **CB** (cool beige), **WG** (warm grey), **CG** (cool grey), **B** (black), **W** (white).

**ColorMatch:**

For available colors, reference ColorMatch, located in the Essentials Palette.

**Floor Finishing Accessories.**

Johnsonite's broad selection of transition accessories helps you glide through a space without interference. Find each of your surface thicknesses in the rows and columns below, then trace down and

across to see where they meet in the middle. There, you'll find the solutions that will help you transition from one surface to another. Smooth. Safe. Seamless.

TRANSITION SELECTOR CHART BY DIMENSION									
For profile drawing and details, see specific accessory categories on pages 196-199.									
Gauge	Subfloor	1/16"	.080"	1/8"	3/16"	1/4"	5/16"	3/8"	1/2"
Subfloor		SSR-XX-B	RRS-XX-B SSR-XX-B SLT-XX-J SLTC-XX-J	SSR-XX-B RRS-XX-C RRS-XX-D SLT-XX-J SLTC-XX-J	EG-XX-J EG-XX-K	CRS-XX-A EG-XX-H CTA-XX-J CTA-XX-JL SLT-XX-L SLTC-XX-L	EG-XX-G EG-XX-L	CRS-XX-B EG-XX-W CTA-XX-P CTA-XX-PL	CRS-XX-D CTA-XX-Q
1/16"	SSR-XX-B						CTA-XX-D		
.080"	RRS-XX-B SSR-XX-B SLT-XX-J SLTC-XX-J		CTA-XX-Y	SLT-XX-B SLTC-XX-B CTA-XX-X SSR-XX-D		SLT-XX-C SLTC-XX-C CTA-XX-HT SLT-XX-H SLTC-XX-H	CTA-XX-D	CTA-XX-Z	
1/8"	SSR-XX-B RRS-XX-C RRS-XX-D SLT-XX-J SLTC-XX-J		SLT-XX-B SLTC-XX-B CTA-XX-X SSR-XX-D	CTA-XX-N FS-XX-DW3		SLT-XX-A SLTC-XX-A CTA-XX-H CTA-XX-HL CTA-XX-A CTA-XX-C CE-XX-A	CTA-XX-D CE-XX-A	CTA-XX-K	CD-XX-B
3/16"	EG-XX-J EG-XX-K								
1/4"	CRS-XX-A EG-XX-H CTA-XX-J CTA-XX-JL SLT-XX-L SLTC-XX-L		SLT-XX-C SLTC-XX-C CTA-XX-HT SLT-XX-H SLTC-XX-H	SLT-XX-A SLTC-XX-A CTA-XX-H CTA-XX-HL CTA-XX-A CTA-XX-C CE-XX-A		CTA-XX-M CD-XX CD-XX-C CD-XX-W	CD-XX CD-XX-C CD-XX-W	CTA-XX-L SLT-XX-F SLTC-XX-F	CE-XX-C SLT-XX-G SLTC-XX-G
5/16"	EG-XX-G EG-XX-L	CTA-XX-D	CTA-XX-D	CTA-XX-D CE-XX-A		CD-XX CD-XX-C CD-XX-W	CD-XX CD-XX-C CD-XX-W	CCA-XX	CWA-XX
3/8"	CRS-XX-B EG-XX-W CTA-XX-P CTA-XX-PL		CTA-XX-Z	CTA-XX-K		CTA-XX-L SLT-XX-F SLTC-XX-F	CCA-XX		CE-XX-C
1/2"	CRS-XX-D CTA-XX-Q			CD-XX-B		CE-XX-C SLT-XX-G SLTC-XX-G	CWA-XX	CE-XX-C	CD-XX-A

**DIMENSIONS BY COLOR**



1. Identify thickness of materials to be transitioned.
2. Find the corresponding color to match the thicknesses.
3. Find your colors together on the chart.



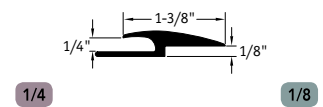

<span style="background-color: #FFD700; border: 1px solid black; border-radius: 50%; padding: 2px;">0</span> = 0"	<span style="background-color: #9932CC; border: 1px solid black; border-radius: 50%; padding: 2px;">1/16</span> = 1/16"
<span style="background-color: #90EE90; border: 1px solid black; border-radius: 50%; padding: 2px;">.080</span> = .080"	<span style="background-color: #4682B4; border: 1px solid black; border-radius: 50%; padding: 2px;">1/8</span> = 1/8"
<span style="background-color: #FFD700; border: 1px solid black; border-radius: 50%; padding: 2px;">3/16</span> = 3/16"	<span style="background-color: #800080; border: 1px solid black; border-radius: 50%; padding: 2px;">1/4</span> = 1/4"
<span style="background-color: #FFD700; border: 1px solid black; border-radius: 50%; padding: 2px;">5/16</span> = 5/16"	<span style="background-color: #3CB371; border: 1px solid black; border-radius: 50%; padding: 2px;">3/8</span> = 3/8"
<span style="background-color: #4682B4; border: 1px solid black; border-radius: 50%; padding: 2px;">1/2</span> = 1/2"	

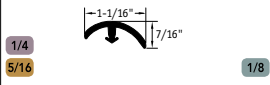
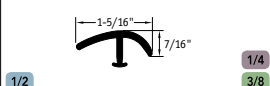
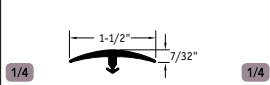
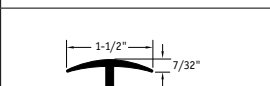
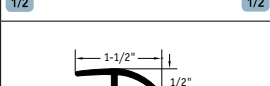
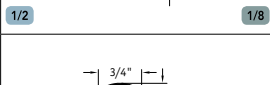

Example: 1/4" 1/4 material to 1/8" 1/8 material.

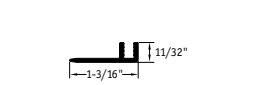

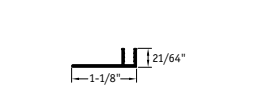
Can't find a transition to meet your needs? Call your Johnsonite® representative and ask about getting a custom floor finishing accessory made for you. New accessories are added periodically, please visit [tarkettna.com](http://tarkettna.com) for the latest additions.

T-MOULDINGS	
<b>CE-XX-A</b> 1/4" and 5/16" to 1/8" material. 1/4" leg.	
<b>CE-XX-C</b> 1/2" to 1/4" and 3/8" material. 1/2" leg.	
<b>CD-XX</b> 1/4" and 5/16" to material of same height. 1/4" leg.	
<b>CD-XX-A</b> 1/2" to material of same height. 1/2" leg.	
<b>CD-XX-B</b> 1/2" to 1/8" material. 1/2" leg.	
<b>CD-XX-C</b> 1/4" and 5/16" to material of same height. 1/4" leg.	
<b>CD-XX-W</b> 1/4" and 5/16" to material of same height. 1/4" leg.	

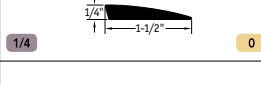
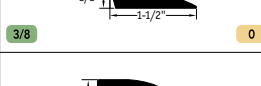
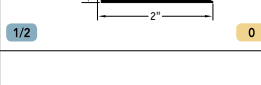
TRACK FOR T-MOULDINGS	
<b>CDB-00-A</b> Rigid Vinyl Pinless for adhesive installations. Neutral color only.	
<b>MT-00-A</b> Aluminum pinless for adhesive installations.	
<b>MTC-00-A</b> Aluminum contour track for adhesive installations. 6" minimum radius.	
<b>MT-00-B</b> Aluminum pin type for stretch-in installations.	
<b>MTC-00-B</b> Aluminum pin type contour track for stretch-in installations. 6" minimum radius.	

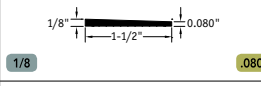
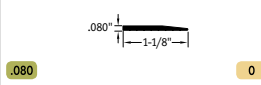
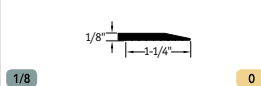
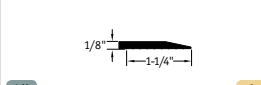
REDUCERS	
<b>CRS-XX-A</b> 1/4" material to floor.	
<b>CRS-XX-B</b> 3/8" material to floor.	
<b>CRS-XX-D</b> 1/2" material to floor.	
<b>SSR-XX-B</b> 35' roll 1/16" or 1/8" material to floor.	
<b>SSR-XX-D</b> 1/8" to .080" material.	
<b>RRS-XX-B</b> 3' pieces .080" material to floor.	
<b>RRS-XX-C</b> 3' pieces 1/8" material to floor.	
<b>RRS-XX-D</b> 25' roll 1/8" material to floor.	

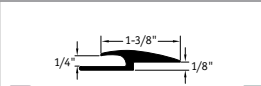
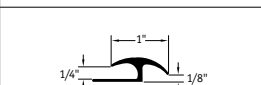
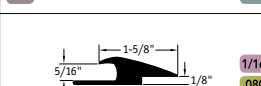
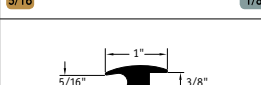
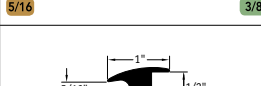
ADAPTORS	
<b>CTA-XX-A</b> 1/4" to 1/8" material.	
<b>CTA-XX-C</b> 1/4" to 1/8" material.	
<b>CTA-XX-D</b> 5/16" to 1/16" or 1/8" material.	
<b>CCA-XX</b> 5/16" to 3/8" material.	
<b>CWA-XX</b> 5/16" to 1/2" material.	

**ColorMatch:**  
For available colors, reference ColorMatch, located in the Essentials Palette.

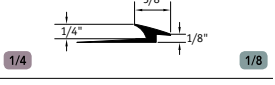
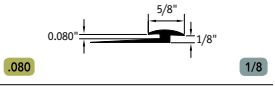
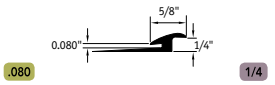
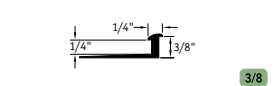
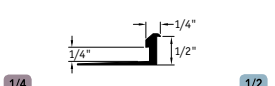
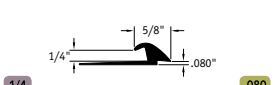
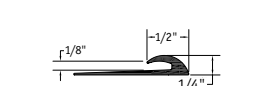
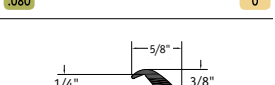
SLIM LINE TRANSITIONS	
<b>SLT-XX-A</b> <b>SLTC-XX-A*</b> 1/4" to 1/8" material.	
<b>SLT-XX-B</b> <b>SLTC-XX-B*</b> .080" to 1/8" material.	
<b>SLT-XX-C</b> <b>SLTC-XX-C*</b> .080" to 1/4" material.	
<b>SLT-XX-F</b> <b>SLTC-XX-F*</b> 1/4" to 3/8" material.	
<b>SLT-XX-G</b> <b>SLTC-XX-G*</b> 1/4" to 1/2" material.	
<b>SLT-XX-H</b> <b>SLTC-XX-H*</b> 1/4" to .080" material.	
<b>SLT-XX-J†</b> <b>SLTC-XX-J*†</b> .080" or 1/8" material to subfloor.	
<b>SLT-XX-L†</b> <b>SLTC-XX-L*†</b> 1/4" material to subfloor.	

\*Slim line transitions available for materials with a contour edge.



Contour image is for demonstration purposes only and is not to scale.

Slim Line Transitions are also available in metallic colors 65 Coronado, 66 Either Ore, 67 Old Gold, 69 Sterling Silver CG, 77 White Pearl W, 82 Black Pearl B, 176 Brass WB, 177 Copper, 178 Ironstone CG, 179 Steel WG.

† Only available in metallic colors. See color guide for metallic colors.

For representation of actual size, enlarge CAD drawing 333% on a photocopy.

We've identified Color Foundations neutrals in the following way: **WB** (warm beige), **CB** (cool beige), **WG** (warm grey), **CG** (cool grey), **B** (black), **W** (white).

**ColorMatch:**

For available colors, reference ColorMatch, located in the Essentials Palette.

WHEELED TRAFFIC TRANSITIONS	
<p><b>CTA-XX-H</b> ✦ Patented 1/4" to 1/8" material.</p> <p>1/4" 1/8" 2-1/2"</p>	<p><b>CTA-XX-M</b> 1/4" to 1/4" material.</p> <p>1/4" 1/4" 2-1/2"</p>
<p><b>CTA-XX-HL</b> ✦ Patented 1/4" to 1/8" material.</p> <p>1/4" 1/8" 4"</p>	<p><b>CTA-XX-N</b> 1/8" to 1/8" material.</p> <p>1/8" 1/8" 2-1/2"</p>
<p><b>CTA-XX-HT</b> ✦ Patented 1/4" to .080" or 2 mm material.</p> <p>1/4" .080" 2-1/2"</p>	<p><b>CTA-XX-P</b> 3/8" material to subfloor.</p> <p>3/8" 0 2-1/2"</p>
<p><b>CTA-XX-J</b> 1/4" material to subfloor.</p> <p>1/4" 0 2-1/2"</p>	<p><b>CTA-XX-PL</b> 3/8" material to subfloor.</p> <p>3/8" 0 4"</p>
<p><b>CTA-XX-JL</b> 1/4" material to subfloor.</p> <p>1/4" 0 4"</p>	<p><b>CTA-XX-Q</b> 1/2" material to subfloor.</p> <p>1/2" 0 4"</p>
<p><b>CTA-XX-K</b> ✦ Patented 3/8" to 1/8" material.</p> <p>3/8" 1/8" 2-1/2"</p>	<p><b>CTA-XX-X</b> ✦ Patented 1/8" to .080" material.</p> <p>1/8" .080" 2-1/2"</p>
<p><b>CTA-XX-L</b> ✦ Patented 3/8" to 1/4" material.</p> <p>3/8" 1/4" 2-1/2"</p>	<p><b>CTA-XX-Y</b> .080" to .080" material.</p> <p>.080" .080" 2-1/2"</p>
<p><b>CTA-XX-Z</b> ✦ Patented 3/8" to .080" material.</p> <p>3/8" .080" 2-1/2"</p>	<p><b>CTA-XX-Z</b> ✦ Patented 3/8" to .080" material.</p> <p>3/8" .080" 2-1/2"</p>

✦ U.S. Patent No. 5,581,967 ✦ U.S. Patent No. 5,611,916 ● U.S. Patent No. 5,624,466

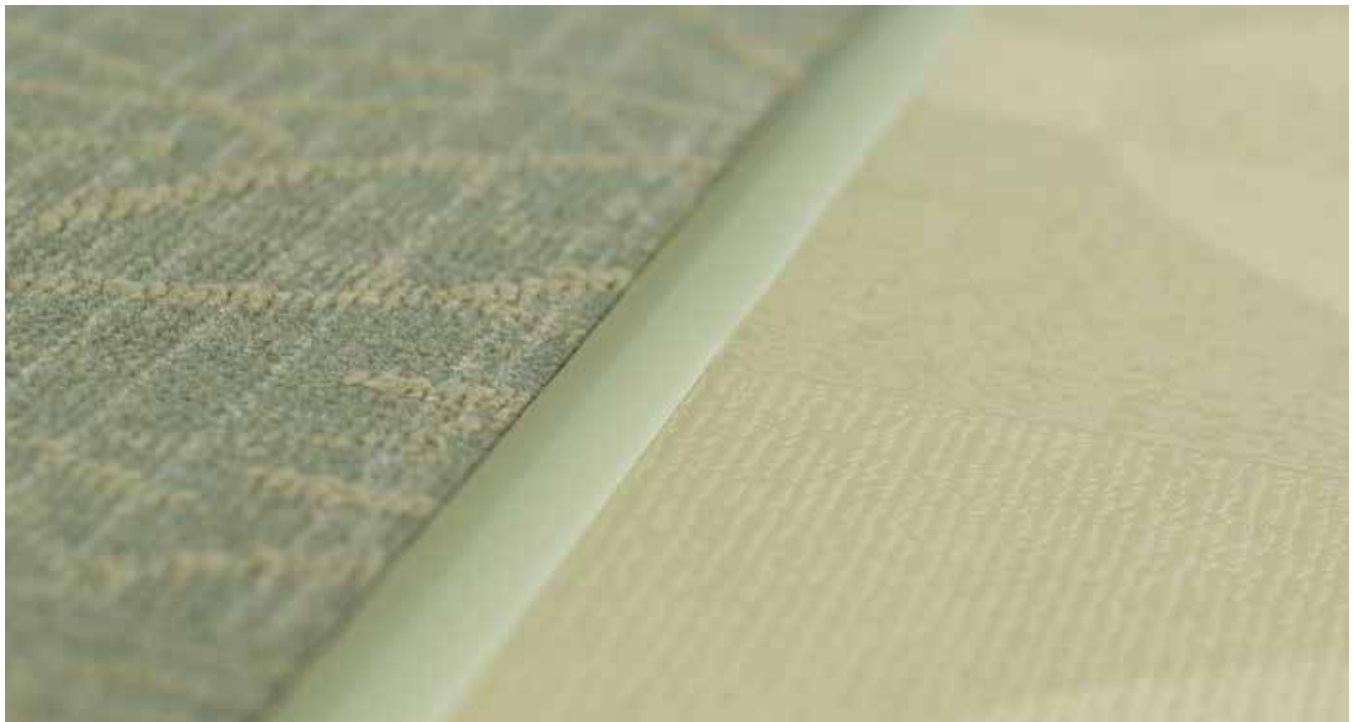

For representation of actual size, enlarge CAD drawing 333% on a photocopy.

We've identified Color Foundations neutrals in the following way: **WB** (warm beige), **CB** (cool beige), **WG** (warm grey), **CG** (cool grey), **B** (black), **W** (white).

**ColorMatch:**

For available colors, reference ColorMatch, located in the Essentials Palette.

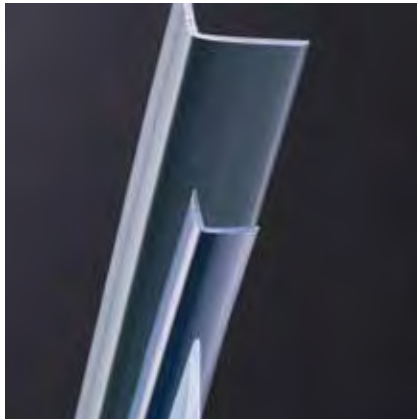

**FLEXIBLE CORNER GUARDS**

Johnsonite's corner guards will not only complement the interior space, but also work to protect your finished design.

- Will not shrink, crack or chip
- Four return sizes: 2-3/8", 1-1/2", 3/4" and 1-1/4"

**color palette availability**

**A** = Essentials Color Palette

**FLEXIBLE VINYL CORNER GUARDS**

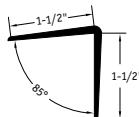
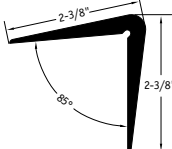
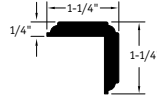
<p><b>VBG-XX-B-48</b> <b>VBG-XX-B-96</b> 4' or 8' pieces</p> <p>Corner guard. 3/4" returns. 1/8" thick. Tapered ends.</p> 	<p><b>VBG-XX-A-48</b> <b>VBG-XX-A-96</b> 4' or 8' pieces</p> <p>Corner guard. 1-1/2" returns. 1/8" thick. Tapered ends.</p> 	<p><b>VBG-XX-48</b> <b>VBG-XX-96</b> 4' or 8' pieces</p> <p>Corner guard. 2-3/8" returns. 1/8" thick. Tapered ends.</p> 	<p><b>VBG-XX-C</b> <b>A</b> 8' pieces</p> <p>Millwork® profile corner guard. 1-1/4" returns. 1/4" thick.</p> 
---	---	--	--

**EDGE GUARDS**

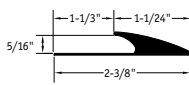
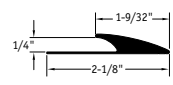
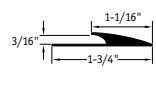
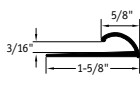
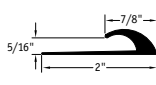
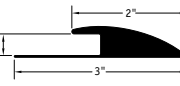
<p><b>EG-XX-G</b></p> <p>5/16" material to floor.</p>	 <p><b>5/16</b> <b>0</b></p>
<p><b>EG-XX-H</b></p> <p>1/4" material to floor.</p>	 <p><b>1/4</b> <b>0</b></p>
<p><b>EG-XX-J</b></p> <p>3/16" material to floor.</p>	 <p><b>3/16</b> <b>0</b></p>
<p><b>EG-XX-K</b></p> <p>3/16" material to floor.</p>	 <p><b>3/16</b> <b>0</b></p>
<p><b>EG-XX-L</b></p> <p>5/16" material to floor.</p>	 <p><b>5/16</b> <b>0</b></p>
<p><b>EG-XX-W</b></p> <p>3/8" material to floor.</p>	 <p><b>3/8</b> <b>0</b></p>

**FEATURE STRIPS**

<p><b>FS-XX-DW3</b> 50' roll</p> <p>1" wide feature strip for 1/8" material.</p>	 <p><b>1/8</b> <b>1/8</b></p>
--	--

**TUB MOULDINGS**

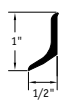
<p><b>TM-50*</b> 5' pieces (self-stick)</p> <p>Luster finish cove for bathtub, counter and shelves. 1-1/2" height.</p>	
<p><b>TM-50-A*</b> 5' pieces (self-stick)</p> <p>Luster finish cove for bathtub, counter and shelves. 1" height.</p>	

\* Available in 50 White W only.